



 **ASKION**
OEM-SERVICES

MEDICAL EQUIPMENT

You have the prototype - we make the serial production

BIOANALYTICS

You have the test - we make the reader

OPTOELEKTRONICS

You have the idea - we put it in optics

**> YOUR RELIABLE OEM-PARTNER FOR THE DEVELOPMENT
AND PRODUCTION MEDICAL AND BIOANALYTICAL DEVICES!**



From l.t.r. Lutz Doms (Managing Director), Martin Druse (Production Manager), Andreas Wolf (Development Manager), Dr. Egon Pfeifer (Manager Marketing & Sales), Lars Riedel (Commercial Management)

Since the company was founded in 2004 ASKION is a reliable and strong OEM partner for the realization of new ideas for devices to serial production. Focus is the development, production and service for medical and bioanalytical equipment as well as optoelectrical and fine mechanical modules for different applications.

We care for our customers all along the product cycle from conception and development to serial production, including all necessary technical approvals.

Trustful collaboration with our customers, the commitment of our employees and the management as well as outstanding professional competence are the focal point of our company philosophy.

➤ **MEDICAL TECHNOLOGY**

➤ **BIOANALYTICS**

➤ **OPTOELEKTRONICS**

Optical technologies are the core of many medical diagnostic techniques and treatment methods.

Benefit from our Know-How as optic expert:

- Fluorescence systems with excitation and detection in one compact system
- Laser assemblies for dermatological and stomatological applications
- Diagnostic imaging systems

We are also a competent and reliable OEM partner for developing and manufacturing complex devices:

- Conception and construction of assemblies and devices
- Development of control, readout and operating electronics including the required software
- Experiences in certification of devices

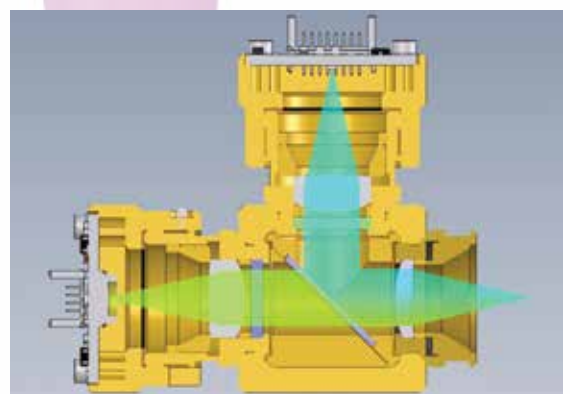
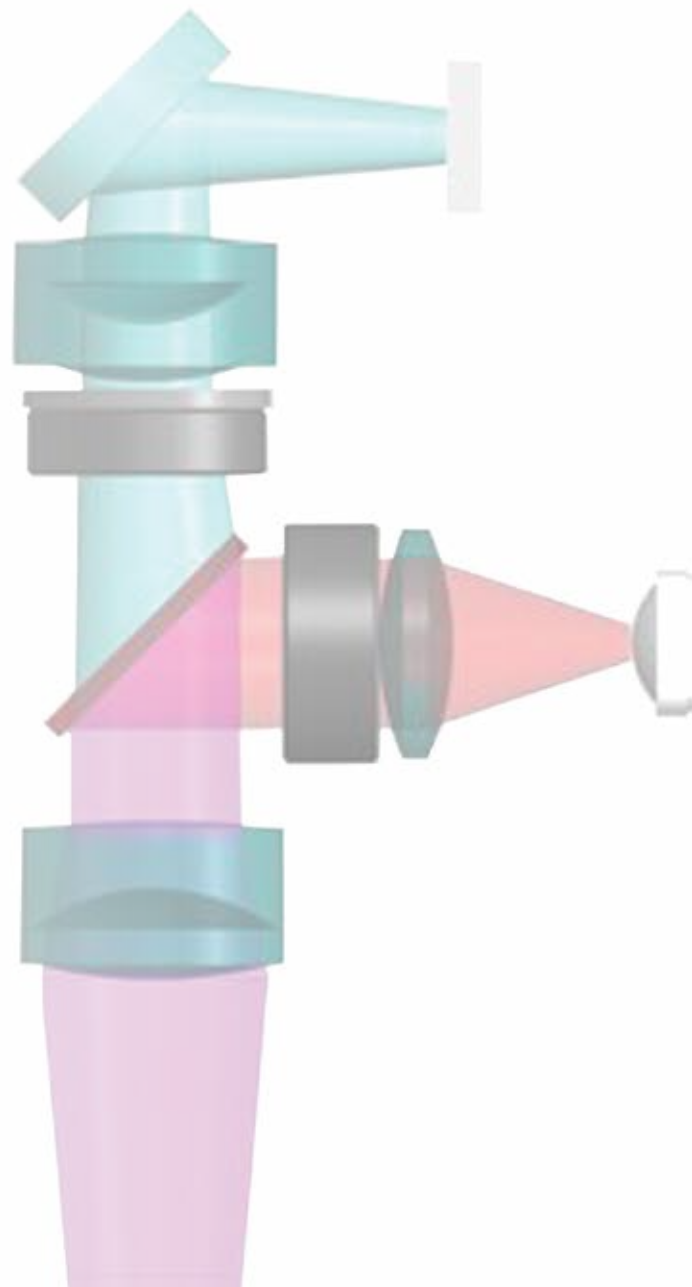

› MEDICAL EQUIPMENT

Resulting from our years of experience and our outstanding Know-How in developing and manufacturing medical equipment as well as our quality management, we are a reliable partner in medical technics. We are certified according to DIN EN ISO 13485 and audited by FDA as „Manufacturer of Medical Devices“.

- › Development of devices and assemblies
- › Efficient and reliable transition to serial production
- › Serial production
- › Qualified personnel and modern assembly area, incl. low-dust production area for optic assembly
- Supply Chain Management

Based on your idea and your requirements we work together with you on the conception. Deliveries of the conception are binding technical, regulatory and economical objectives for the development of the device or assembly. A detailed project plan and a project controlling ensure a reliable timetable and cost analysis.

TYPICAL APPLICATIONS

- › Devices for optical diagnostics
- › Visualization and image evaluation
- › Fluorescence optical assemblies and systems
- › Laser modules and assemblies
- › Illumination systems



› BIOANALYTICS

We invite you to benefit from our long-term experience in the development and production of systems for bioanalytical applications including optical excitation and detection for immuno and molecular diagnostics. According to your assay development we design a tailor-made reader for your specific application.

We develop the complete device including hard- and software. In addition we develop illumination and excitation modules and detection modules according to your required wavelength and signal. We also design traveling and positioning of the detector or the array.

Our modular ASKION fluorescence modules can be adapted to your requirements.

- › Laser diode and LED modules
- › Fiber coupled laser sources
- › Fluorophore specific filter selection
- › Camera detection
- › Photo diodes/APD detectors
- › Photomultiplier

TYPICAL APPLICATIONS

- › Real-time PCR-Reader
- › Quantitative detection of fluorescence
- › Fluorescence imaging
- › Confocal fluorescence scanner

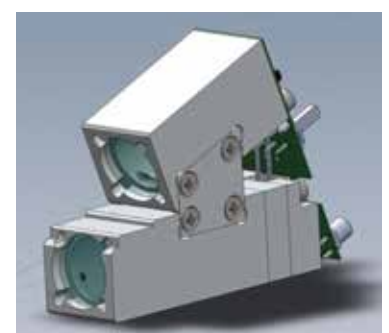
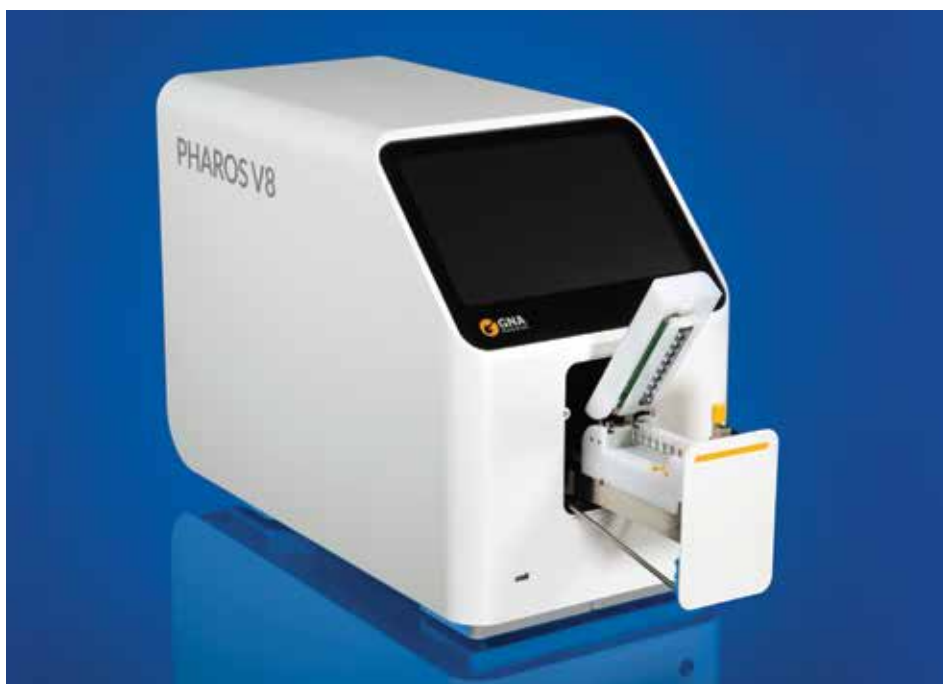
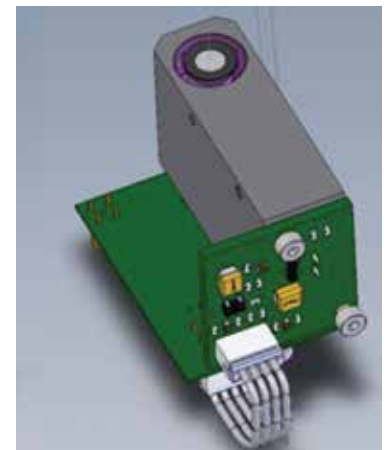

› OPTOELEKTRONICS

Depending on your technical requirements and your scheduled costs and quantities we design and develop (ZEMAX) the optical system as well as the hardware and mechanics around. Our research and development department is equipped with a modern optical lab.

High qualified employees guarantee high-end manufacturing of complex systems. The optic manufacturing is provided with dust and ESD safe areas.

TYPICAL APPLICATIONS

- › Optics for beam shaping
- › Laser and LED modules
- › Fiber optical assemblies
- › CCD and CMOS camera modules
- › Scanning systems
- › Imaging and excitation systems



> REFERENCES

We develop and manufacture devices and assemblies as OEM partner for many of our costumers, for example:

MEDICAL EQUIPMENT



BIOANALYTICS



OPTOELEKTRONICS



› RESEARCH & DEVELOPMENT

SYSTEMS ENGINEERING

- › Integration of optics, mechanics, hard- and software
- › Project management
- › Development and assembling of feasibility, prototypes and transition to serial production, including documentation and approval according to specific regulatory affairs

OPTIC DESIGN

- › Conception, development and optimization of optoelectronic systems
- › Optic design with ZEMAX

MECHANICAL DESIGN

- › Mechanical design of fine mechanical assemblies and devices (SolidWorks), incl. Product-Life-Cycle- and Product-Date-Management
- › Structure analysis using FEM
- › Thermo mechanical simulation with calculation of heat transfers, convection and thermal radiation

ELEKTRONICS

- › Circuit and circuit board design (Altium Designer), redesign and optimization of existing electrical assemblies
- › Premeasurement of EMC during development and analysis using lab equipment like artificial mains network, spectrum analyzer, antennas and near field probes
- › ESD-testing

SOFTWARE

- › Development of application software (Visual Studio)
- › Data base development (MySQL and MSSql)
- › Programmable logic controller (PLC, like Beckhoff or TwinCAT)
- › Microcontroller development (Atmel Studio)
- › Embedded Linux (Qt, gnu-tool chain)
- › Programming of digital signal processors (DSP)

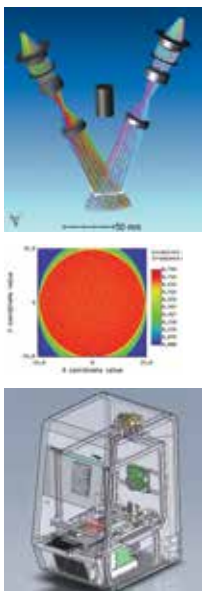

› PRODUCTION

TRANSITION TO SERIAL PRODUCTION

- › Transfer to serial production of devices and assemblies including „Design to manufacturing“ and „Design to cost“
- › Creation of production documentation
- › Planning of adjustment and test strategies
- › Development and assembling of mounting and test equipment

PROTOTYPING

- › Mechanical workshop for quick manufacturing of small quantities or adapting (turning, milling, metal sheet machining)
- › Own cable manufacture for small quantities
- › Prototype construction



SERIAL PRODUCTION

- › Assembling, commissioning and testing of medical and bioanalytical systems
- › Mounting of optoelectrical, fine mechanical and Laser assemblies
- › Planning of production processes and their continuous improvement
- › Low-dust, ESD-protected and air-conditioned production area for optic assembly
- › Procurement, incl. selection of suppliers and suppliers evaluation (more than 100 certified suppliers)
- › Incoming goods inspection
- › Packing and shipment

SUPPORT

- › Continuous implementation of measures for improvement
- › Alteration service
- › Service and customer support
- › Training measures



› QUALITY MANAGEMENT

All processes in development and production comply with high quality standards, especially the requirements for medical devices. Next to the certifications EN ISO 9001 and 13485 we are audited by FDA as „Manufacturer of Medical Devices“.

RESEARCH AND DEVELOPMENT

- › Planning and documentation of the whole development process compliant to actual standards (Design History File)
- › Implementation of software lifecycle management processes according to DIN EN 62304:2007-03
- › Validation of processes and devices
- › Verification of climate, storage, vibration and transportation conditions

Specific quality requirements will be fixed in quality assurance agreements in collaboration with our costumers.

PRODUCTION

- › Process monitoring, error tracking, CAPA, 8D (Device History Record)
- › Implementation of test strategies
- › Development and realization of complex test equipment
- › Change management
- › Supplier monitoring



➤ REGULATORY AFFAIRS

Especially in medical engineering and diagnostics the regulatory requirements increased. For that reason we expanded our product portfolio for technical approval and the preparation of the necessary documents.

- Risk analyses according to DIN EN ISO 14971:2012
- Laser safety according to DIN EN 60825
- Electrical safety according to DIN EN 60601
- Premeasurement for EMC and ESD

Documentation and monitoring according to the requirements of specific medical approvals:

- CEMed annex II, section 3 of the directive 93/42/EWG
- IVD directive 98/79/EC
- FDA

